

Arrow 5

UV-LED Water Treatment System

USER'S MANUAL



SUMMARY

This document is the product manual for the Arrow 5, and includes safety, product specifications, installation, and maintenance information.

Table of Contents

Product Overview	3
Safety Information and Warnings	4
Warnings and Safety Precautions	4
Product Information	5
Specifications	5
Overview of Your Arrow 5 Water Treatment System	5
Installation Guide	6
Installation Instructions	7
Mounting the Unit	8
Conditioning and Powering the Unit	8
Indicator Light	8
Maintenance	9
Regular Maintenance	9
Winterizing	9
Trouble Shooting	9
Standard Terms and Conditions	10
Warranty	10
Appendix A: Faucet Installation Instructions	11

PRODUCT OVERVIEW

Congratulations on the purchase of your Arrow 5 UV-LED Water Treatment System. This is our high-performance system that is ideally suited for single faucet applications, ice-makers, and water fountain upgrades. It fits easily under a sink in a home, cottage, RV or boat, and is convenient and low maintenance.



EPA Est. No: 98339-CAN-1

SAFETY INFORMATION AND WARNINGS

This section contains important information regarding the safe installation and operation of the Arrow 5 (the “device”). **PLEASE READ CAREFULLY.**

Installation or operation of the device in a manner contrary to this manual may result in property damage or personal injury.

Acuva recommends that the device be installed by a qualified technician who complies with applicable state and local regulations.

Warnings and Safety Precautions

DANGER

Do not store the device in freezing conditions.

Do not allow water to freeze in the device.

Do not use the device if damaged or dropped.

Do not submerge the device under water.

Do not connect to AC power without an AC to DC power adapter; this device uses DC only.

This product is not ignition protected. Do not install in an engine compartment or other areas where explosive vapours may be present.

WARNING

A steady blue indicator light (illuminating the Acuva logo) on the device and smart faucet (if installed) while water is flowing is the only indication that the system is working. If the blue light is not lit while the faucet is open, please check the “Troubleshooting” section of this manual.

The UV device includes fragile parts, including parts made from glass. The device should not be dropped and must be transported/carried with sufficient care.

Install the device in an accessible and visible location for continuous monitoring of the LED indicators and/or in case of any leakage.

CAUTION

Minor condensation may occur on the device in humid weather and with cold water temperatures (less than the dew point temperature). Condensation drips may be noticed coming from inside the unit.

PRODUCT INFORMATION

Specifications

Dose Delivery	>16 mJ/cm ²
Flow Rate	5 L/min
Water Inlet Fitting	3/8" OD Push-to-Connect
Water Outlet Fitting	3/8" OD Push-to-Connect
Input Voltage	11-16V DC
Power Consumption (Active)	Approx. 60W
Power Consumption (Standby)	Approx. 0.1W
Maximum Water Temperature	40°C
Maximum Working Pressure	100 PSI
Minimum Working Pressure	40 PSI
LED Life-time	3,000 hr (on demand)
Maximum Ambient Relative Humidity	70%

Overview of Your Arrow 5 Water Treatment System

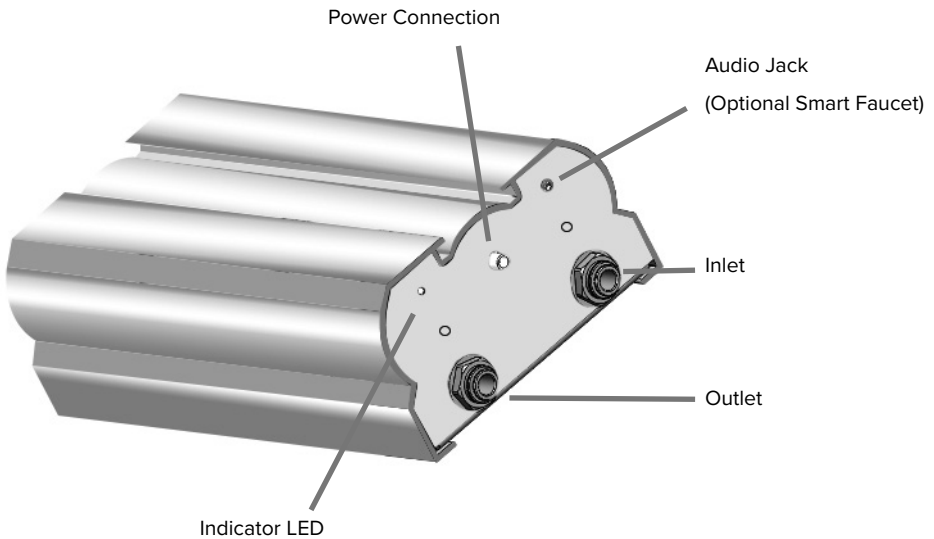

INSTALLATION GUIDE

Acuva systems are designed for ease of installation. Two different installation scenarios are shown below: when the Arrow 5 is connected to a dedicated smart faucet (A) or when it's connected to the main faucet (B).

(A) Installation with Smart Faucet

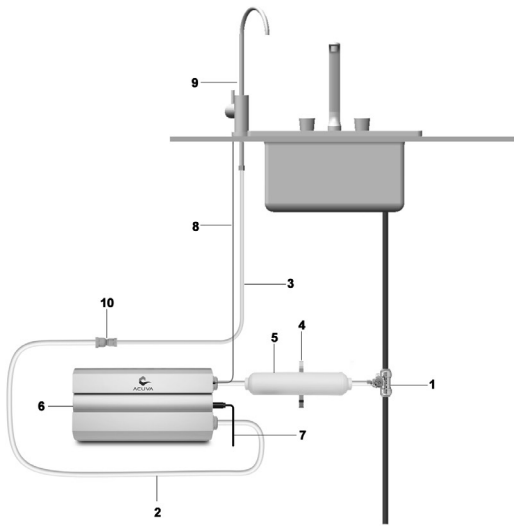

(B) Installation without Smart Faucet

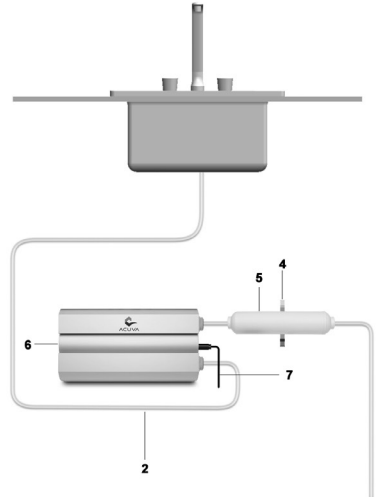

Item No.	Description	Quantity
1	1/2" PEX to 1/4" OD Tee/Shut-off Valve	1
2	3/8" OD Tube	1
3	1/4" OD Tube	1
4	Filter Clip	1
5	In-line Filter	1
6	Arrow 5.0	1
7	Power Plug Cable	1
8	Smart Faucet Cable	1
9	Smart faucet	1
10	3/8" to 1/4" Reducing Union Straight	1

INSTALLATION GUIDE

Arrow 5 Installation

1. Find an under-counter position for the Arrow 5 device and pre-filter to be mounted, allowing space for the tubing to be connected without needing to bend the tube to the point of pinching or folding.
2. Mount the DIN-rail (shown in the “Mounting the Unit” diagram) that will support the device with two #10 wood screw and the filter clip (item no. 4) for the pre-filter with the two remaining screws.
3. To install the 1/2” PEX-3/8” OD Tee & shutoff valve (item no. 1) to the cold- water line, ensure the cold-water line is not under pressure by turning off the water and/or cutting the flow with an upstream valve. Expect some water to drain from the cold-water line while cutting. Insert the 1/2” cold- water lines to the 1/2” female ends of the Tee, pushing the tubes into the Tee as far as possible and pulling gently to assure that the seal is secure.
4. Cut a length of 3/8” tubing (item no. 2) that will connect the Tee to the pre-filter (item no. 5). Feed the compression nut and brass ferrule over the tubing, and insert the tubing into the tee. Use a wrench to firmly tighten the compression nut until the tubing stays in place when pulled.
5. Connect the 3/8” tube from the Tee into the inlet side of the pre-filter while making sure that water will flow in the proper direction as indicated on the filter. Push the tube into the filter as far as possible and pull gently to ensure it is properly sealed. Snap the pre-filter into its wall- mounted clips.
6. To install the Arrow 5 (item no. 6), mount it to the DIN-rail as seen in the “Mounting the Unit” figure.
7. Cut a length of 3/8” tubing that will connect the pre-filter to the Arrow 5’s inlet and push both ends of the tubing into place, and pull on each gently to ensure it is properly sealed.
8. Cut a length of 3/8” tubing that will connect the UV device and the smart faucet (item no, 9) using a straight reducer adapter (item no. 10) and connect the 1/4” OD tubing (item no.3) to the desired water faucet or appliance. For each push-fit connection, pull the tubing gently after installation to ensure it is secure and sealed.

For faucet installation instructions, see Appendix A.

Mounting the Unit

ORIENTATION

Recommended: Horizontally on the wall /
Floor or ceiling any direction

Not Recommended: Vertically on the wall



INSTALLATION GUIDE

Mounting the Unit

1. Engage the spring-loaded mechanism of the mounting clips on the device by hooking the clip onto the bottom edge of the DIN-rail and applying slight pressure upwards.
2. As bottom portion engages, tilt the upper hook towards the DIN-rail.
3. Release the spring mechanism once the unit is mounted on the rail.

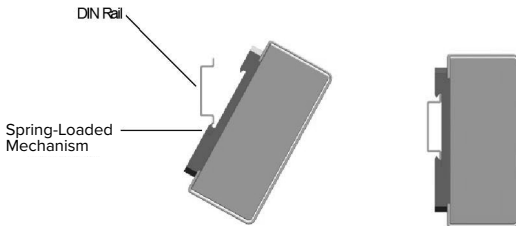

Conditioning and Powering the Unit

For DC power source applications, installing a 10A 250V slow blow fuse will provide additional electrical protection

1. Once the device is connected to the cold-water line, allow water to flow through the system for 1-2 minutes until any bubbles are released from the line. During this time, ensure all connections are tight and sealed.
2. Connect the DC power source or AC to DC power adapter to the device. Hand-tighten the nut to the threaded jack to secure it.



WARNING

Do not use a wrench or pliers to tighten the plug or power jack as this may cause damage to the device.

3. If there is no water flow on powering up, the Acuva logo should glow green for 30 seconds.
4. Turn on the faucet. The logo will glow blue which indicates the UV-LEDs are working. If the smart faucet is installed, its base will glow blue as well.
5. Turn off the faucet and the device will automatically go into standby mode.

Indicator Light

The Acuva logo lights up to indicate various modes of use.

No Light: The device is idle or no power is connected.

Blue Light: The device is active.

Green Light: The device is undergoing its self-cleaning protocol. This 30 second protocol occurs at start up as well as after every 12 hours of idle time and can be interrupted to dispense water.

Note: If there is a fault, the indicator light will turn red or yellow. Please consult the Troubleshooting section.

MAINTENANCE

The Arrow 5 is designed to give years of trouble-free use. Acuva products use state-of-the-art UV-LEDs, meaning there are no bulbs to replace. However, there are some simple tasks that should be performed to ensure continued operation.

Regular Maintenance

1. Check monthly that none of the connectors are leaking.
2. Replace the in-line filter after winterization or as per the instructions on the filter label.

Note: The small quartz windows inside the Arrow 5 unit do not reach high temperatures to encourage mineral build-up (scaling) as with UV lamp systems. As a result, no significant scaling or loss of performance due to scaling over time is expected.

Winterizing

WARNING

Frozen pipes mean cracked pipes. Failure to properly winterize the Acuva unit before it is exposed to freezing temperatures can lead to damage and water leakage.

If the device is installed in a Recreational Vehicle (RV) ensure that the RV is winterized as per its owner's manual.

TROUBLE SHOOTING

Indicator LED State	Fault Condition	Comments to User
Off (No water flow)	No Fault	-
Off (Water flow)	The unit is not powered	Verify that the unit is connected to power and that the input voltage is within specifications (11-16V).
	The flow direction is reversed	Ensure the inlet and outlet tubes are connected to the respective fittings marked "IN" and "OUT" on the device.
	The flow rate is too low	The flow sensor inside the unit requires a minimal water flow to activate the system (approx. 0.3 Lpm). Ensure there is enough water pressure in the line to reach this flow.
Red	UV-LED fault	Unplug and plug in the device's power jack. If this fault persists, contact Acuva for support.
Blinking Yellow	Low input voltage	Verify that the input voltage is above 11 volts.
Blinking Red	Over-Temperature Fault	Turn the device off and allow time for it to cool down and clear the error. If the device repeatedly enters this state, contact Acuva for support.

STANDARD TERMS & CONDITIONS

The sale and use of all Acuva products is governed by the Acuva Technologies Inc. Standard Terms and Conditions of Sale and Use (the “Agreement”), a copy of which is available at www.acuvatech.com.

The Agreement contains important terms that, among other things, affect Acuva’s liability and your legal remedies against Acuva. Please read the Agreement carefully as, by purchasing the Acuva product, you have agreed to be bound by the entire Agreement including the limited warranty, limitations of liability and methods of resolving disputes. In the event of any inconsistency between this manual and the Agreement, the Agreement shall prevail.

WARRANTY

As set out in the Agreement, Acuva products come with the following limited warranty.

Limited Warranty

SCOPE AND PERIOD

Acuva warrants to you that the Product will be free from defects in materials and workmanship under normal use for 1 year from the original date of purchase by you (the “Warranty Period”). The limited warranty in this Agreement (the “Limited Warranty”) is not transferable by you. All subsequent purchasers acquire the Product “as is” without benefit of the Limited Warranty. Where you purchased the Product from Acuva’s Site or other online vendors the date of purchase is the date of the purchase invoice issued to you by Acuva or such online vendors by email. Where you purchased the Product from an authorized reseller at a physical location, the date of purchase is the date of the invoice issued to you at the physical location.

DEFECTS

In the event Acuva determines that the Product is defective, Acuva may in its discretion: (i) replace the defective Product with a new Product; or (ii) refund to you the purchase price you paid for the Product. ‘DEFECTS’ SECTION IS NOT APPLICABLE TO RESIDENTS OF QUEBEC.

REPLACEMENT

Where the Product is replaced during the Warranty Period, except as otherwise prohibited by applicable laws, the warranty for the replaced Product, as applicable, will expire upon the expiration of the original Warranty Period. Any warranty service or support under this Limited Warranty is conditioned upon your return of the Product to Acuva. Where there has been a replacement of the Product, the Product, as provided pursuant to this limited warranty, becomes your property and the Product being replaced becomes Acuva’s property. Where there is a refund, you will return the Product to Acuva and such Product becomes Acuva’s property. Acuva may condition a refund or replacement on you returning the product or require you to provide a credit card number, which will be charged only if you fail to return the Product. ‘REPLACEMENT’ SECTION IS NOT APPLICABLE TO RESIDENTS OF QUEBEC.

WARRANTY

EXCLUSIONS

The limited warranty does not apply:

1. To normal wear and tear;
2. If the Product was not purchased from Acuva or its authorized retailers;
3. To damage caused by misuse, corrosion, moisture or liquids, proximity or exposure to heat or external environment, accident, abuse, misuse, neglect, improper installation or misapplication;
4. To physical damage to the Product;
5. To any software, whether or not supplied by Acuva.

APPENDIX A: FAUCET INSTALLATION INSTRUCTIONS

1. Drill a 3/4" hole into the counter-top where the Smart Faucet will be inserted.
2. Thread the faucet cable into the 3/4" hole and insert the faucet stem into the hole.
3. Thread the faucet power cord through the plastic spacer under the counter to ensure that the cord is not pinched against the counter when the faucet is fastened into place, making sure that the spacer's O-ring seal is facing up to seal against the counter.
4. Add the plastic threaded fastener to the faucet stem and tighten the fastener against the spacer to secure the faucet into place. Make sure that the faucet is positioned properly as required before tightening the fastener.
5. To connect the 1/4" water line to the faucet stem, slip the hex nut onto the tube, followed by the plastic ferrule and plastic tube support. Press the tube end and ferrule to the bottom of the faucet stem and tighten the hex nut by hand, then tighten the nut with a over-tighten.

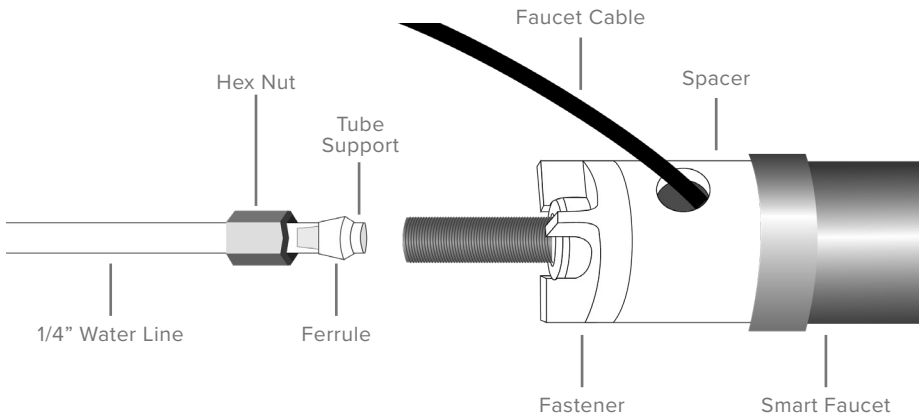



Acuva Technologies Inc.

Unit 1 - 3771 North Fraser Way, Burnaby, BC. Canada V5J 5G5

Telephone: 1-800-980-8810 | Email: hello@acuvatech.com

acuvatech.com | acuvastore.com



[#acUVatech](https://www.facebook.com/acuvatech)

[@acuvatech](https://www.instagram.com/acuvatech)